



# BRP-Powertrain CHASSIS APPROVAL FORM



<b>Manufacturer</b>	Gillard Racing Karts Ltd.
<b>Chassis model</b>	010B V2
<b>Category</b>	ROTAX MAX Challenge, 125 MAX DD2 class
<b>Validity of approval</b>	without limitation
<b>Date of approval by BRP-Powertrain</b>	2010 08 26

<b>Technical definition of the frame</b>
Built according to CIK regulations for short circuits karts

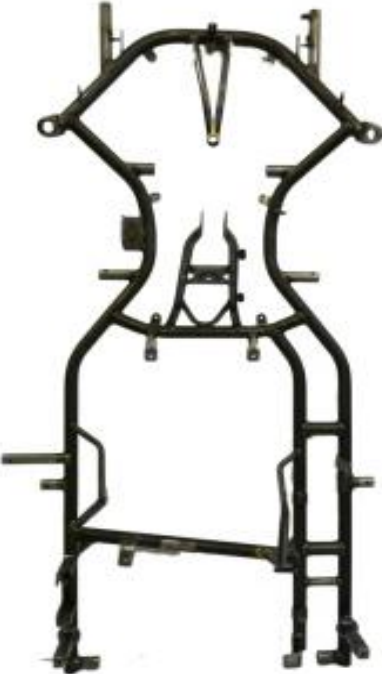
<b>Technical definition of the components of the chassis</b>	
Brake system:	Designed according to CIK rules for shifter classes. A brake system with a valid CIK Homologation must be used.
Bodywork:	Designed according to CIK rules for short circuit karts. A bodywork with a valid CIK Homologation must be used.
Rear Tire Protection System:	For the participation at national or international ROTAX MAX Challenge race, the BRP-Powertrain Rear Tire Protection System must be used.

	
Photo from above of the frame (without any mounted part)	Photo of the identification plate of the frame with the name of the chassis model.

Technical description	Dimensions	Tolerance
Outer diameter of the main tubes (without painting)	30	+/- 0,5 mm
Rear width of main tubes (center line to center line)	606	+/- 5,0 mm
Distance of the rear two main tubes on the right side (center line to center line)	102	+/- 0,5 mm
Wheelbase	1050	+/- 5,0 mm

Technical description	Figure
Number of adjustable/removeable stabilizers at the frame	2

**BRP-Powertrain CHASSIS APPROVAL FORM**



Photo from above of the frame with the section of the engine mount



Photo from above of the frame with the section of the two supports for the exhaust system



Foto of the frame with the section of the support for the fuel pump (fuel pump mounted)



Foto of the frame from the side with the section of the supports for the radiator (radiator mounted)

**BRP-Powertrain CHASSIS APPROVAL FORM**



Photo from the steering column with the section with the knurling for the steering wheel hub (knurling according to DIN 82 - RAA1).



Photo from above of the frame with the section of the two supports for the RTPS (Rear Tire Protection System)



Photo of the frame from the side with the section of the support for the RTPS (Rear Tire Protection System)



Photo of the frame from the back with the section of the support for the RTPS (Rear Tire Protection System)